

User Guide

Excavator Forks



Product Information Overview

The Conquip Excavator Forks attachment is designed to enable an excavator to lift palletised material. This is especially useful if space is restricted and budget is limited, as it ensures you only need one machine on site.

Available in three sizes, to suit excavators ranging from 5 to 50 tonnes

Key Benefits

- Quick and simple to attach, with adjustable pin centres and different pin sizes to suit any model of excavator quick hitch.
- Ability to see through the unit allows clear visibility of pallet/load for the excavator operator.
- Fork tines can be folded over the unit for compact storage.
- ‘Floating’ forks allow for easier placement and easier lifting on uneven surfaces.
- Excavator Forks 1000 can be supplied with 45, 50 or 60mm pins to suit 5 to 9 tonne excavators.
- Excavator Forks 2000 can be supplied with 65 or 80mm pins to suit 13 to 22 tonne excavators.
- Excavator Forks 4000 can be supplied with 90, 100 or 110mm pins to suit 30 to 50 tonne excavators.
- Forks sit as a free standing unit, flat to the ground when unattached.
- Manufactured in the UK from British and EU steel.
- Can be supplied with anti-slide plate and backrest for extra load stability.

Product Information Specification

Item	Product Code
Excavator Forks 1000	EA010AP-01000
Excavator Forks 2000	EA010AP-02000
Excavator Forks 4000	EA010AP-04000

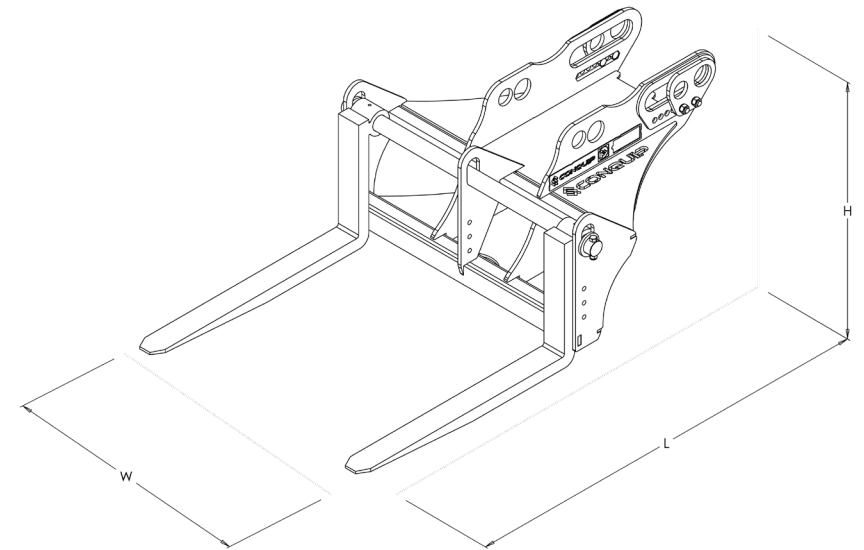

¹Working Load Limit

Product Code	Height	Width	Length	Weight	WLL ¹
EA010AL-01000	540mm	1010mm	1930mm	195kg	1000kg
EA010AP-02000	640mm	1230mm	2110mm	345kg	2000kg
EA010AO-04000	745mm	1390mm	2740mm	540kg	4000kg

Original Working Instructions

Usage Instructions

Important Usage Notes

- If there is a slinger / signaller they should not be positioned underneath the load and should remain visible to the driver.
- Operators should allow for any rough or sloping ground when assessing the method of operating.

Using with an Excavator

1. Select relevant size pins to match your machine's quick hitch.
2. Fit front pin to correct sized hole on the Excavator Forks.
3. Adjust the position of rear pin to suit the quick hitch- follow the quick hitch operating guidelines and set the pins to the maximum centres for the unit.
4. Ensure the quick hitch pins have the retaining bolts and washers and they are correctly fitted.
5. Check for debris in the quick hitch locking mechanism and check the fit of the unit on the quick hitch, do not use if not secure.
6. Adjust the fork width to suit the job by sliding the forks along the top bar. Position the forks in the widest practical position.
7. Tighten the fork tine retaining screws to fix the position. The forks on this unit are floating, pivoting around the top rail.
8. When lifting or setting down loads always operate the forks in a horizontal plane.
9. When traveling with a load keep it in the lowest practicable position and maintain driver visibility.
10. Once the Excavator Forks are no longer needed, lower to the ground and release from the quick hitch. The fork tine retaining screws can then be loosened and the fork tines lifted back over the body of the attachment to reduce the space required for storage.

Original Working Instructions

Safety Instructions

Basic Safety

A site-specific Risk Assessment, and lift plan where applicable, must be completed by the responsible person before using this equipment to control risks, produce a safe system of work and ensure safety for you, your colleagues and others. Your risk assessment will determine the correct Personal Protective Equipment (PPE) for the task you are doing. You must use it. Conquip recommends that you should wear:

- Suitable clothing
- Gloves
- Hard hat
- Protective footwear (steel toecaps)
- Safety glasses



Important Safety Notes

- Read these instructions before using this equipment. If there is anything you do not understand or if you have any concerns do not use this equipment. Contact your supervisor or Conquip Engineering Group for advice.
- You must check that you have considered all the safety requirements for the task you are doing and that this equipment is suitable.
- You must protect bystanders and the general public by preventing access to the working area.
- Do not use this equipment if you are tired, unwell or under the influence of alcohol or drugs. If you are taking any medicine or undergoing treatment you should inform your supervisor.

Usage & Transportation

- Never unevenly load this equipment.
- The weight of the equipment, together with its attachments, must be added to the weight of the load when calculating the total load that will be imposed on the lifting apparatus / operating machine.
- This equipment must be used in conjunction with the load ratings of the lifting apparatus / operating machine. (Refer to the manufacturers' load ratings and original working instructions).
- Make sure you know how to use this equipment and understand all aspects of its operation in case of emergency.
- This equipment weighs more than 25kg. Do not lift or manhandle without machine assistance.
- Do not operate this equipment near overhead power lines.
- Take care in confined spaces, near ceilings or similar hazards. This equipment was designed for vertical lifting. Do not drag, or swing.
- Before operating this equipment, check that you have enough space for you to work safely and make sure that the working area is clear of hazards, obstructions and personnel.
- Before lowering equipment make sure that the landing zone is clear and capable of accepting the size and weight of the load.
- Crush Risk. Keep hands and feet clear of the equipment at all times to avoid injury.
- Do not exceed the maximum Working Load Limit (WLL) shown on the serial plate. Ensure that the WLL on the individual lift points is not exceeded.
- Before lifting, check that the load is secured, balanced and stable. Allow space for the equipment to move if the load shifts.
- Manoeuvre loaded or raised equipment carefully. Travel and turn slowly to avoid unit becoming unstable.

Personnel

- All personnel must wear relevant personal protective equipment.
- Do not wear loose clothing or jewellery and tie back long hair to avoid becoming tangled or trapped in this equipment. You must make everyone in the work area aware of what you are doing.
- All personnel involved in the lifting operation must be competent to do so and must have been briefed in conjunction with this User Guide available from Conquip Engineering Group, the manufacturer.

Equipment Maintenance & Cleaning

- It is mandatory that the equipment is thoroughly examined regularly, by a qualified engineer, to ensure compliance with relevant regulation/s. (Conquip recommend to carry out thorough examination every six months).
- This product may incorporate various loose and detachable items of lifting gear. Refer to the separate requirements for the safe use of those items.
- When not being used, store the unit in a clean, upright condition and in a safe place where it will be protected from thieves and unauthorised users.
- This equipment must be inspected by the responsible person before each use and then regularly, as determined by your risk assessment or working practice. If you have any concerns about condition or suitability do not use.

Disclaimer

Warranty

The products supplied by Conquip Engineering Group are all guaranteed by a 12 month warranty.

Apart from where exceptions apply, Conquip Engineering Group promises to repair or replace any fault which the Company considers to be due to defective material or workmanship within 12 months of the date of sale, at no additional cost.

- Faults arising from unauthorised alterations (see modifications section below for full details).
- Damage caused by abuse, neglect, misuse or falling.
- Damage caused because of failure to follow transportation, storage, loading, cleaning or operating instructions.
- Replacement or repair of components due to fair wear and tear.
- Any consequential damage or wear arising from the use or fitting of additional or non-standard parts.

Modifications

If any third-party modifications or alterations, involving drilling, welding, cutting or distortion of materials in any form, are to be carried out on the product, Conquip Engineering Group must provide full written approval prior to the work being carried out.

Alterations, modifications, additions or repairs must be carried out by Conquip Engineering Group's recognised distributors, if they are not carrying out the work themselves.

Conquip Engineering Group operate a continuous improvement policy and therefore reserve the right to alter technical specifications and user guide details at any point without notice.

Conquip Engineering Group will not cover or reimburse any transportation and/or shipment costs to and from their premises or their recognised agents, or any material and/or labour costs for repair, replacement or assessment against a warranty claim.

Conquip Engineering Group and/or their directors, employees, insurers or recognised agents will not be held liable for consequential damages, losses or expenses relating to the inability to use the product correctly for its purpose.

EC Declaration of Conformity

In accordance with EN ISO 17050-1:2004

Declaration: As defined by the Machinery Directive 2006/42/EC and subsequent amendments

We, CONQUIP ENGINEERING GROUP, herewith declare that the following indicated equipment meets the fundamental health and safety requirements concerning the EU guide line(s), due to their design and manufacture.

This declaration will be rendered null and void if the machine is changed without our approval.

Signed:



Dated: 2019

Garry Critchley, Managing Director

Product Code(s):

EA010AP-01000 / EA010AP-02000 / EA010AP-04000

EC Directive/ Regulation:

2006/42/EC,
Lifting Operations and Lifting Equipment Regulations 1998
Provision and Use of Work Equipment Regulations 1998

Harmonised Standards:

BS EN ISO 12100:2010

General Description/ Designation:

Excavator Forks – EA010AP-01000 / EA010AP-02000/ EA010AP-04000

WLL:

EA010AP-01000 = 1000kg
EA010AP-02000 = 2000kg
EA010AP-04000 = 4000kg

Important Notes

- This User Guide is for this Conquip product only.
- Any movements of the product must be thoroughly planned before the work commences to identify potential hazards and assess risk.
- All personnel involved in lifting and transportation of this product must have read this User Guide and must be properly briefed.
- You must be competent, alert and medically fit when using this equipment. If you have a medical condition, a mental or physical disability, you must seek advice from a medical professional before using this equipment.

Talking to us is easy

We're here to help

Call us on 0845 520 1101

Email us at sales@cqegroup.com

www.cqegroup.com

Conquip Engineering Group

Waterbrook Estate, Alton, Hampshire, GU34 2UD