

Yale®

Electric Chain Hoist

Model CPV/F

Capacity 250 kg - 2.000 kg

Translated Operating- and Maintenance Manual

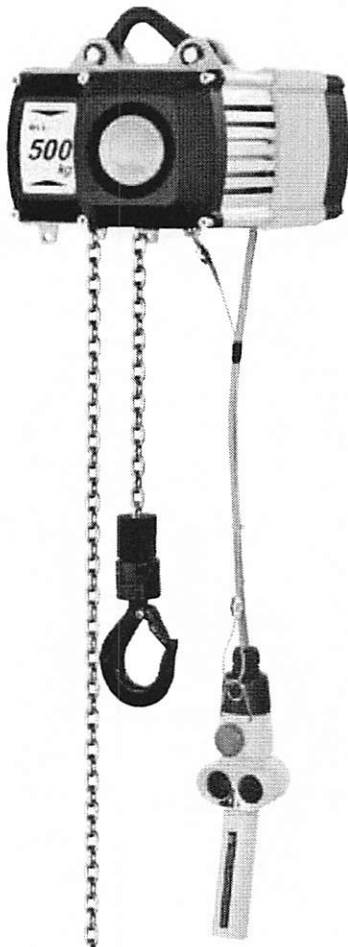

Columbus McKinnon Industrial Products GmbH

Postfach 10 13 24 • D-42513 Velbert, Germany

Am Lindenkamp 31 • D-42549 Velbert, Germany

+49 20 51/600-0 • Fax +49 20 51/600-127

Ident.-No.: 09901076/08.2011



COLUMBUS MCKINNON



Yale Electric Chain Hoist CPV/F

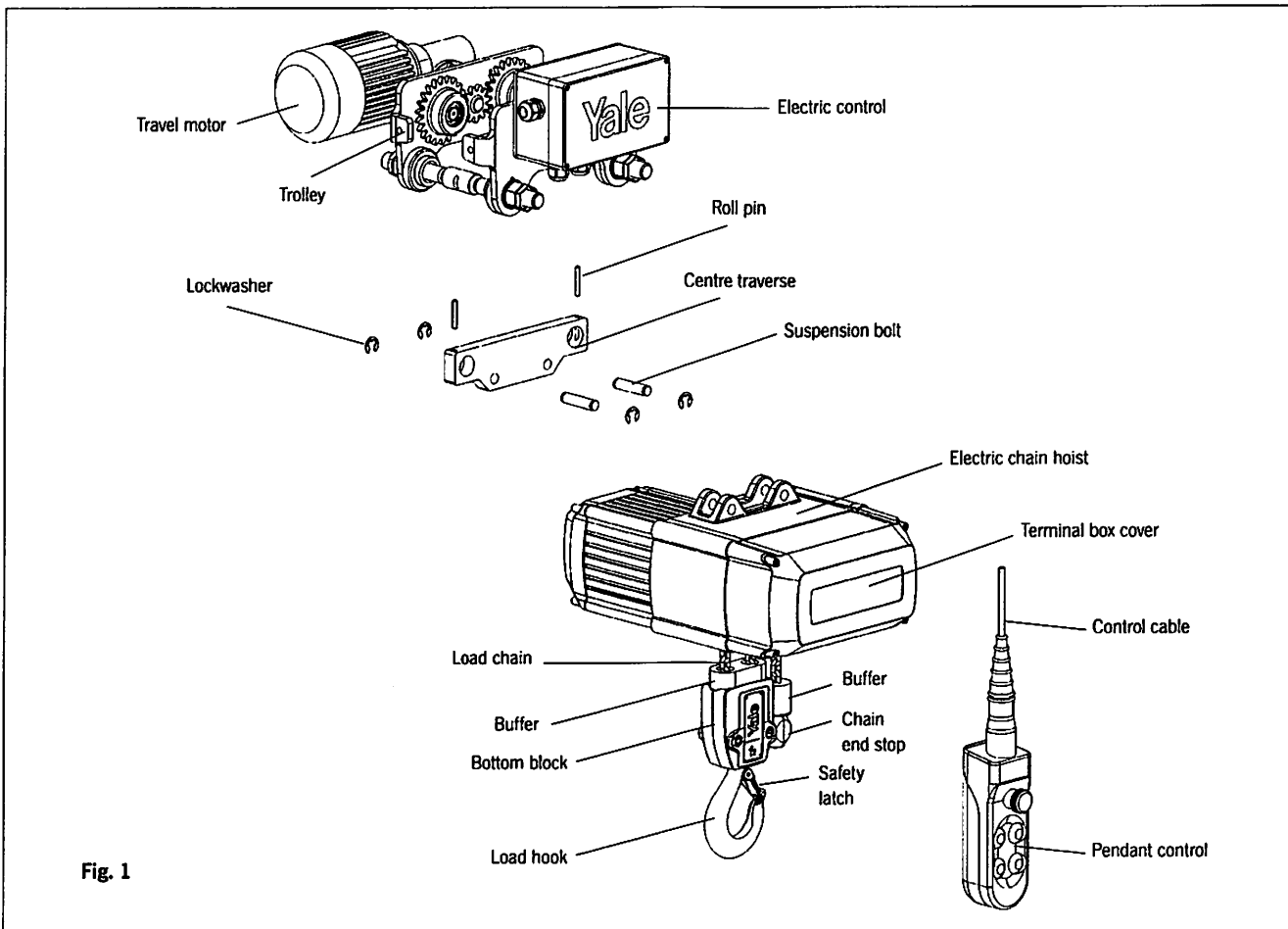

Fig. 1

Technical data electric chain hoist

Technical data electric trolley

Model	Capacity [kg]	Number of chain falls	Motor rating* ED [%]	Motor* [kW]	Lifting speed(s)** [m/min]	FEM group	Beam widths [mm]	Curve radius min [m]	Travel speed(s)*** [m/min]	Motor [kW]	Motor rating* ED [%]
CPV 2-8 CPVF 2-8	250	1	50	0,37	8	1 Am	58 - 180 or 180 - 300	0,9	18	0,18	40
17/33			0,09/0,37	2/8	4,5/18				0,06/0,18		
CPV 2-20 CPVF 2-20	250	1	50	0,75	20	1 Am	58 - 180 or 180 - 300	0,9	18	0,18	40
17/33			0,18/0,75	5/20	4,5/18				0,06/0,18		
CPV 5-4 CPVF 5-4	500	2	50	0,37	4	1 Am	58 - 180 or 180 - 300	0,9	18	0,18	40
17/33			0,09/0,37	1/4	4,5/18				0,06/0,18		
CPV 5-8 CPVF 5 - 8	500	1	50	0,75	8	1 Am	58 - 180 or 180 - 300	0,9	18	0,18	40
17/33			0,18/0,75	2/8	4,5/18				0,06/0,18		
CPV 5-20 CPVF 5 -20	500	1	50	1,5	20	1 Am	58 - 180 or 180 - 300	1,15	18	0,18	40
17/33			0,37/1,5	5/20	4,5/18				0,06/0,18		
CPV 10-4 CPVF 10 - 4	1.000	2	50	0,75	4	1 Am	58 - 180 or 180 - 300	0,9	18	0,18	40
17/33			0,18/0,75	1/4	4,5/18				0,06/0,18		
CPV 10-8 CPVF 10 - 8	1.000	1	50	1,5	8	1 Am	58 - 180 or 180 - 300	1,15	18	0,18	40
17/33			0,37/1,5	2/8	4,5/18				0,06/0,18		
CPV 20-4 CPVF 20-4	2.000	2	50	1,5	4	1 Am	58 - 180 or 180 - 300	1,15	18	0,18	40
17/33			0,37/1,5	1/4	4,5/18				0,06/0,18		

*230V/3Ph/50 Hz, 400V/3Ph/50 Hz, 460V/3Ph/60 Hz

**Speed(s) CPV 10-8 at 230V, 1 Ph, 50 Hz = 4 m/min Speed(s) CPV 20-4 at 230V, 1 Ph, 50 Hz = 2 m/min

***Optionally available with 11 m/min.



TABLE OF CONTENTS	PAGE
1. General information	3
2. Correct operation	3
Maximum capacity	3
Danger zones	3
Attaching the hoist/trolley	3
Temperature range	4
Regulations	4
Maintenance/repair	4
3. Incorrect operation	4
4. Assembly	4
4.1 Inspection before assembly	4
4.2 Electric chain hoist with suspension bracket	4
4.3 Electric chain hoist with trolley	5
Assembly of the trolley	5
Assembly, shortening or extending the hand chain	6
4.4 Electrical connection	6
Preparation	6
Connecting to the power supply	6
5. Functional test after assembly	8
6. Commissioning	8
Inspection before initial operation	8
7. Operation	8
Installation, service, operation	8
Inspection before starting work	8
Inspection of load chain	8
Inspection of chain end stop	8
Inspection of chain reeving	8
Inspection of load hook	8
Attaching the load	8
Inspect the traverse (for trolleys)	8
Check adjustment of trolley width	8
Traversing the trolley	8
Attaching the load	9
Lifting/lowering the load	9
Emergency stop	9
Limit switch	9
8. Service	9
8.1 Daily checks	9
8.2 Regular inspections, service and testing	10
8.3 Load chain	10
Lubricating the load chain	10
Inspecting the load chain for wear	10
Replace the load chain	10
1-strand design, 2-strand design	10
8.4 Maintenance of load hook	11
8.5 Maintenance of trolley	12
8.6 Maintenance of overload protection	12
Overload protection	12
Adjustment of overload protection	12
8.7 Maintenance of gearbox	12
Oil change	12
8.8 Maintenance of motor	13
Motor	13
Spring activated disc brake	13
Changing of rotor with friction lining	13
Disassembly of disc brake	13
8.9 Electric chain hoist in general	13

1. GENERAL INFORMATION

Attention: All users must read these operating instructions carefully prior to the initial operation. These instructions are intended to acquaint the user with the hoist/trolley and enable him to use it to the full extent of its intended capabilities.

The operating instructions contain important information on how to handle the hoist/trolley in a safe, correct and economic way. Acting in accordance with these instructions helps to avoid dangers, reduce repair costs and downtime and to increase the reliability and lifetime of the hoist/trolley.

Anyone involved in doing any of the following work with the hoist/trolley must read the operating instructions and act accordingly:

- Operation, including preparation, trouble shooting and cleaning
- Maintenance, inspection, repair
- Transport

Apart from the operating instructions and the accident prevention act valid for the respective country and area where the hoist/trolley is used, also the commonly accepted regulations for safe and professional work must be adhered to.

The user is responsible for the proper and professional instruction of the operating personnel.

Every unit leaving the factory is furnished with a test certificate that shows the serial number of the hoist/trolley. This certificate has to be filed together with the inspection manual.

The continuous sound level at the place of work is equal to <70 dB. The measures were taken at a distance of 1 m from the hoist at 9 positions in accordance with DIN 45635, precision class 2.

2. CORRECT OPERATION

Maximum capacity

The Yale electric chain hoist series CPV/F has been designed to lift and lower loads up to the rated capacity. The lifting capacity indicated on the hoist/trolley is the maximum safe working load which must not be exceeded.

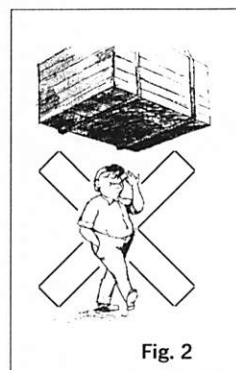

Fig. 2

Danger zones

- Do not allow personnel to pass under a suspended load (see Fig. 2).
- After lifting or tensioning, a load must not be left unattended for a longer period of time.
- Start moving the load only after it has been attached correctly and all personnel are clear of the danger zone.

Attaching the hoist/trolley

The operator must ensure that the hoist/trolley is attached in a manner that does not expose himself or other personnel to danger by the hoist, trolley, chain(s) or the load.



Yale Electric Chain Hoist CPV/F

Temperature range

The units can be operated in ambient temperatures between -10°C and +40°C. Consult the manufacturer in case of extreme working conditions.

Attention: At ambient temperatures below 0°C check the brake is not frozen.

Theoretical service life

The electric chain hoist is classified to group 1Am according to FEM 9.511. Basic principles for the calculation of the theoretical remaining service life are given in BGV D8. When the theoretical remaining service life has been reached, the electric chain hoist should be subjected to a general overhaul (also refer to para 8. Maintenance).

Regulations

The accident prevention act and/or safety regulations of the respective country for using manual and electric hoists must be strictly adhered to. In Germany these are BGV D6, BGV D8, BGR 500 and VDE 0113-32 / EN 60204-32: 1999.

Maintenance/Repair

In order to ensure correct operation, not only the operating instructions, but also the conditions for inspection and maintenance must be complied with. If defects are found or abnormal noise is to be heard stop using the hoist / trolley immediately.

Attention: Before starting work on electrical components the power supply is to be cut off.

3. INCORRECT OPERATION

- Do not exceed the rated capacity of the hoist/trolley.
- Do not lift stuck or jammed loads.
- Excessive inching operation by short and frequent actuation of the control switch should be avoided.
- Do not use the hoist/trolley for the transportation of people (Fig. 3).
- Welding on hook and load chain is strictly forbidden. The load chain must never be used as a ground connection during welding (Fig. 4).

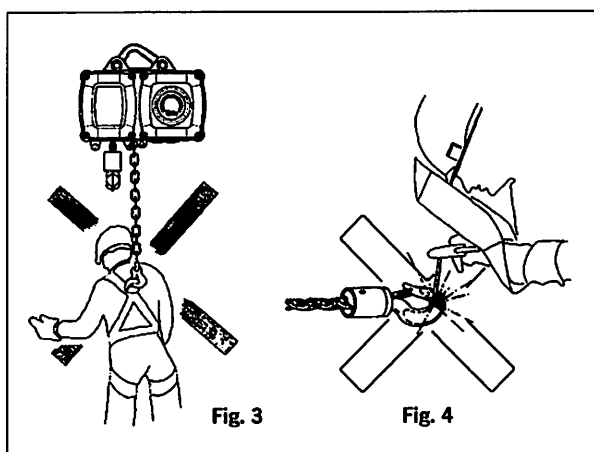

- Side pull, i.e. lateral load on either housing or bottom block (Fig. 5) is not permitted.
Lift only when the load chain forms a straight line between suspension bracket and hook.
- The load chain must not be used for lashing purposes (sling chain) (Fig. 6).

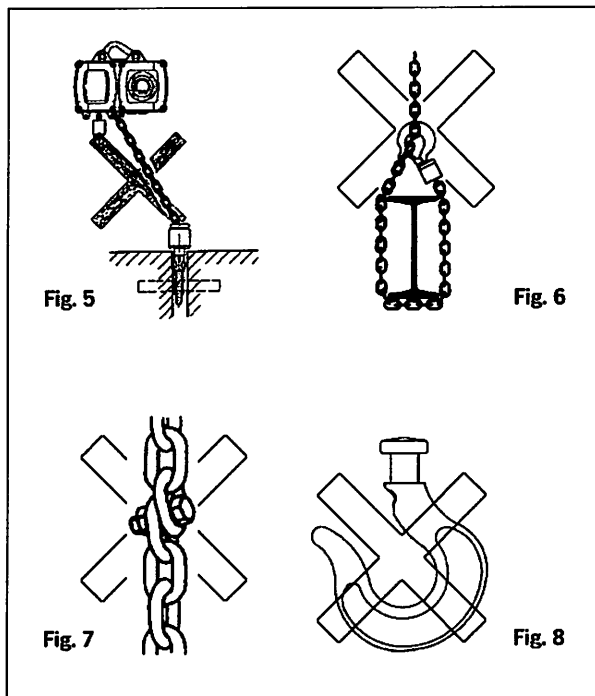

- Do not knot or shorten the load chain by using bolts, screws, screwdrivers or other devices (Fig. 7). Do not repair chains installed in the hoist.
- Do not remove the safety latch from the load hook (Fig. 8).
- Do not use the chain end stop as an operational limit device (see Fig. 1 - chain end stop).
- Do not throw the hoist or trolley down. Always place it properly on the ground.
- The unit must not be operated in potentially explosive atmospheres.
- The longitudinal downward slope of the carriageway must not exceed 0,3%.
- The adjustment of the trolley width must not be extended in order to e.g. obtain a smaller radius curvature.
- Any modifications of the hoist or trolley are prohibited.
- Load can not fall into the loose chain - risk of chain break!
- Never attach the load to the tip of the hook (Fig. 14). The load must always be seated in the saddle of the hook. This also applies to the suspension hook.
- Turning of loads under normal operating conditions is not allowed, as the bottom blocks of the hoists are not designed for this purpose. If turning of loads is required as standard, the bottom blocks have to be provided with swivel hooks supported by axial bearings. In case of queries consult the manufacturer. When turning a lifted load the load chain must not rotate in any circumstances.
- Never attach more than one load lifting attachment to the load hook of the hoist or trolley.

4. ASSEMBLY

4.1 INSPECTION BEFORE ASSEMBLY

- Check for transport damage
- Check for completeness
- Check that the capacity indication on hoist and bottom block match.



4.2 ELECTRIC CHAIN HOIST WITH SUSPENSION BRACKET

(Standard version)

The standard version of the Yale electric chain hoist is provided with a suspension bracket. The bracket is connected with the housing of the chain hoist by means of two bolts. Make sure that the load hook – irrespective of the reeving – is always positioned vertically under the suspension bracket (see Fig. 9).

On single strand units, the suspension bracket is installed with the long bracket side to the right, on dual strand units with the long bracket side to the left (see Fig. 9).

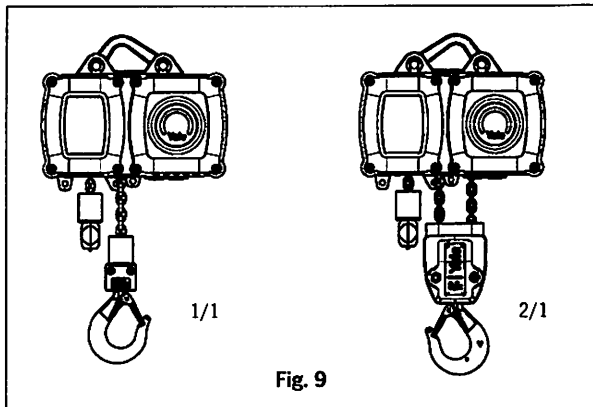

Fig. 9

Attention: Do not forget to fit the lock washers after installation of the suspension bracket.

The load bearing structure must be calculated to safely accept the entire driving forces.

4.3 ELECTRIC CHAIN HOIST WITH TROLLEY

The units are delivered pre-assembled and are built to fit beam range A or B which is given on the name plate (Tab. 1). Prior to installation ensure that the flange width is within the limits indicated.

Beam range	Flange width [mm]		Flange thickness [mm] max.
	min.	max.	
A	58	180	27
B	180	300	27

Tab. 1

Assembly of the trolley (see Fig. 10)

1. Unscrew the locking nuts (item 9) and hex. nuts (item 2) from the crossbars (item 1) and remove both side plates (item 6) from the trolley.

2. Measure the flange width of the beam (see Fig. 10 - measure b).

3. Adjust measure B between the shoulders of the round nuts (item 5) on the threaded crossbars (item 1). Ensure that the 4 bores in the round nuts face towards the outside. Adjust the measure B to equal measure b plus 4 mm. Measure A must be 2 mm on either side and the suspension traverse (item 4) must be centred between the round nuts.

4. Replace one side plate (item 6):

Replace one side plate ensuring that the roll pins (item 8) engage into one of the bores in the round nuts. To achieve this it may be necessary to rotate the round nuts slightly.

5. Replace the washers (item 3) and tighten the hex. nuts (item 2). Screw on the locknuts (item 9) fingertight and tighten a further ¼ to ½ turn.

Attention: The locknuts must always be fitted.

6. Loosely replace the second side plate (item 6) on the crossbars (item 1). The washers (item 3), hex. nuts (item 2) and locknuts (item 9) can be fitted loosely.

7. Raise the complete pre-assembled trolley to the carrying beam.

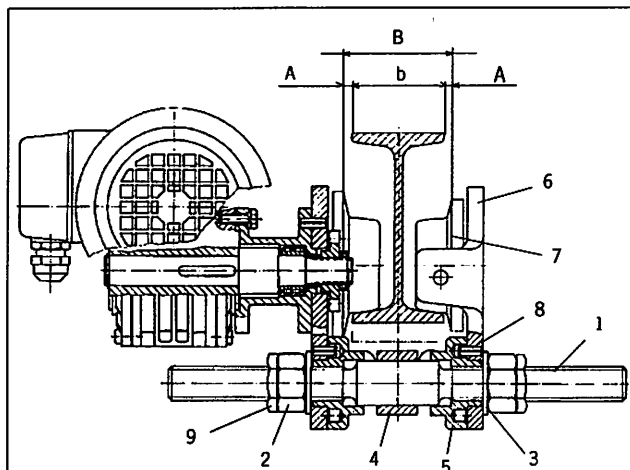

No. Description

- | | | | |
|---|-----------------|----|---------------|
| 1 | Crossbar | 6 | Side plate |
| 2 | Hex. nut | 7 | Trolley wheel |
| 3 | Washer | 8 | Roll pin |
| 4 | Centre traverse | 9 | Locknut |
| 5 | Round nut | 10 | Roll pins |

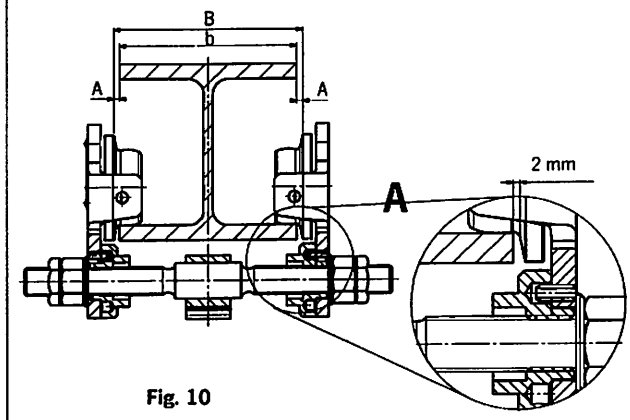
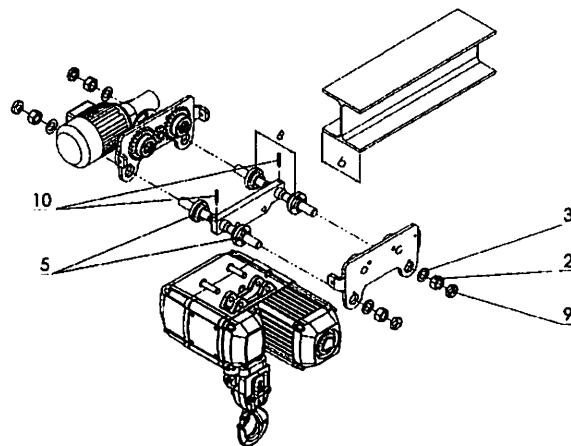

Fig. 10



Yale Electric Chain Hoist CPV/F

8. Engage the second side plate (item 6) ensuring that the roll pins (item 8) engage into one of the bores in the round nuts (item 5). To achieve this it may be necessary to rotate the round nuts slightly.

9. Tighten the hex. nuts (item 2) on the second side plate. Tighten the locknuts (item 9) fingertight and then a further $\frac{1}{4}$ to $\frac{1}{2}$ turn.

Attention: The locknuts must always be fitted.

10. By traversing the trolley check the following:

- that a clearance of 2 mm is maintained on each side between the trolley wheel flanges and the beam outer edge.
- that the suspension traverse is centred below the beam.
- that all 4 locknuts (item 9) are fitted.
- that the side plates are parallel.
- that all wheels roll freely and make good contact with the flange of the beam.
- that there are no obstacles on the driving surface.

Assembly of the hand chain

(Model VTG with hand chain drive only)

To fit the hand chain position the slot on the outer edge of the hand chain wheel below the chain guide. Place any one link of the endless hand chain vertically into the slot and turn the hand chain wheel until the link has passed the chain guides on both sides.

Attention: Do not twist the hand chain when fitting!

Geared trolleys are moved by pulling the hand chain.

Shortening or extending the hand chain

(Model CPV/F with hand chain drive only)

The length of the hand chain should be adjusted so that the distance to the floor is 500 - 1000 mm.

1. Determine the open link of the hand chain and open up by bending.
2. Shorten or extend the hand chain as required.

Attention: The number of removed or added chain links must always be even.

3. Close the open connecting link by bending.

4.4 ELECTRICAL CONNECTION

Attention!

Work at electrical installations may be carried out by electrical experts only. The local regulations have to be strictly observed, e.g. EN 60204-32 / VDE 0113.

Preparation

- Before beginning work on electrical components the mains current switch must be switched OFF and secured against unintentionally being switched back on.
- Before connecting the chain hoist ensure that the electrical data on the nameplate match the local supply specifications.
- The length of the pendant control cable is determined by working conditions. Attach the tension relief wire in a manner that the pendant control cable hangs load-free.
- Wiring diagrams are included with the hoist.

Mains supply connection 3 phases

- The mains supply cable must be an insulated cable with 4 flexible leads. The ground (earth) lead must be longer than the live leads. The cross-section should be min. 1,5 mm², the cable length should be max. 50 m. For the fusing of the various models see tables on page 7. Cable ends have to be provided with end sleeves.

Mains supply connection 1 phase

- The mains supply cable must be an insulated cable with 3 flexible leads. The ground (earth) lead must be longer than the live leads. The cross-section should be min. 1,5 mm², the cable length should be max. 50 m. For the fusing of the various models see tables on page 7. Cable ends have to be provided with end sleeves.

Connecting to the power supply

- The mains supply cable must be connected to the electric chain hoist before it is connected to the mains supply.

Mains supply connection 3 phases

- On chain hoists with an electric trolley (CPV/F-VTE/F), the three phases of the mains supply are to be connected to the terminal strip within the control box on the trolley. The ground/earth wire is then to be connected to a special protective terminal inside the control box of the hoist.
- On chain hoists without electric trolley, the mains supply cable is connected to the circuit board located behind the housing cover (Fig. 18, Pos. 3). The U-type cable shoe of the ground/earth wire must be screwed to the core lamination (do not forget the serrated washer).
- Check the motor's direction of rotation.
- The wiring diagram included has been drawn for a normal, clockwise rotating installation. Should the user's mains supply not fulfil these requirements, e.g. the hoist lowers when lift is selected (or vice versa), switch the unit OFF immediately and exchange two of the three phase connections in the terminal box.
Under no circumstances may the wiring in the pendant control be tampered with.

Mains supply connection 1 phase

- On chain hoists with an electric trolley (CPV/F-VTE/F), the N-conductor, phase and protective earth conductor are connected to the appropriate terminal strips within the control box on the trolley.
- On chain hoists without electric trolley, the mains supply cable is connected to the terminal strip of the plate for hoist control (Fig. 18, item 3).

Attention! The settings of the time relay (ZR) must not be changed!

Attention! Open the housing only 3 minutes after disconnecting the unit from the mains supply. There is the danger of electrical shock by not yet discharged capacitors.

- After replacing the terminal box cover, connect the other end of the supply cable to the disengaged mains switch and power supply system respectively.

Yale Electric Chain Hoist CPV/F



Motor data CPV 230V - 1 Ph - 50 Hz

Model	P [kW]	n [1/min]	ED [%]	Capacitors	I _n [A]	cos φ	Number of circuits [c/h]	Protection degree	Operation mode	Fuse* [A]
CPV 2-8, CPV 5-4	0,5	2730	25	CA = 60μF/CB = 16μF	3,3	0,99	150	IP55	S3	16
CPV 5-8, CPV 10-4	1,0	2800	25	CA = 100μF/CB = 30μF	6,0	0,99	150	IP55	S3	16
CPV 10-4, CPV 20-2	0,75	1400	25	CA = 60μF/CB = 30μF	5,0	0,98	150	IP55	S3	16

Motor data CPV 230/400V - 3 Ph - 50 Hz

Model	P [kW]	n [1/min]	ED [%]	Kind of connection	I _n [A]	cos φ	Number of circuits [c/h]	Protection degree	Operation mode	Fuse* [A]
CPV 2-8, CPV 5-4	0,37	2890	50	delta/Y	1,38/0,8	0,99	300	IP55	S3	6
CPV 2-20, CPV 5-8, CPV 10-4	0,75	2890	50	delta/Y	2,8/1,6	0,99	300	IP55	S3	10
CPV 5-20, CPV 10-8, CPV 20-4	1,5	2860	50	delta/Y	5,5/3,2	0,98	300	IP55	S3	16

Motor data CPVF 400V - 3 Ph - 50 Hz

Model	P [kW]	n [1/min]	ED [%]	Kind of connection	I _n [A]	cos φ	Number of circuits [c/h]	Protection degree	Operation mode	Fuse* [A]
CPVF 2-8, CPVF 5-4	0,09/0,37	640/2850	17/33	Y/Y	0,55/1,0	0,59/0,78	200/100	IP55	S3	6
CPVF 2-20, CPVF 5-8, CPVF 10-4	0,18/0,75	620/2800	17/33	Y/Y	0,95/2,0	0,65/0,82	200/100	IP55	S3	10
CPVF 5-20, CPVF 10-8, CPVF 20-4	0,37/1,5	640/2780	17/33	Y/Y	1,60/3,3	0,64/0,89	200/100	IP55	S3	16

Motor data CPV 460V - 3 Ph - 60 Hz

Model	P [kW]	n [1/min]	ED [%]	Kind of connection	I _n [A]	cos φ	Number of circuits [c/h]	Protection degree	Operation mode	Fuse* [A]
CPV 2-8, CPV 5-4	0,44	3480	50	Y	0,8	0,85	300	IP55	S3	6
CPV 2-20, CPV 5-8, CPV 10-4	0,9	3480	50	Y	1,6	0,86	300	IP55	S3	10
CPV 5-20, CPV 10-8, CPV 20-4	1,8	3450	50	Y	3,2	0,86	300	IP55	S3	16

Motor data CPVF 460V - 3 Ph - 60 Hz

Model	P [kW]	n [1/min]	ED [%]	Kind of connection	I _n [A]	cos φ	Number of circuits [c/h]	Protection degree	Operation mode	Fuse* [A]
CPVF 2-8, CPVF 5-4	0,11/0,44	770/3420	17/33	Y/Y	0,55/1,0	0,59/0,78	200/100	IP55	S3	6
CPVF 2-20, CPVF 5-8, CPVF 10-4	0,25/0,90	740/3360	17/33	Y/Y	0,95/2,0	0,65/0,82	200/100	IP55	S3	10
CPVF 5-20, CPVF 10-8, CPVF 20-4	0,44/1,8	780/3380	17/33	Y/Y	1,60/3,3	0,64/0,89	200/100	IP55	S3	16

*Attention: Delayed-action fuse



Yale Electric Chain Hoist CPV/F

5. FUNCTIONAL CHECK AFTER ASSEMBLY

Prior to initial operation of the hoist, grease the trolley pinions (manual, geared and electric trolleys) and lubricate the load chain when it is not under load (see page 9).

Before the hoist is put into regular service, following additional inspections must be made:

- Are all screwed connections on hoist and trolley tight and are all locking devices in place and secure?
- Are the end stops on the trolley runway in place and secure?
- Is the chain drive correctly reeved?
- The chain end stop must be correctly fitted to the loose end of the load chain (see Fig 1 - chain end stop).
- All units equipped with two or more chain strands should be inspected before initial operation for twisted or kinked chains. The chains of 2-strand hoists may e.g. be twisted if the bottom block is rolled over.
- Check the function of the limit switch by running the buffers of the chain end stop resp. bottom block against the limit switch underneath the housing. The lifting resp. lowering operation must be stopped immediately.
- Check the brake function when lifting and lowering.
- Traverse the trolley (if available) the complete length of the trolley runway ensuring that the 2 - 4 mm lateral clearance between the trolley wheel flange and the beam outer edge is maintained at all times. Check that beam end stops are positioned correctly and secure.

6. COMMISSIONING

Inspection before initial operation

Each hoist/trolley must be inspected prior to initial operation by a competent person and any failures be removed. The inspection is visual and functional. These inspections have to assure that the hoist is safe and has not been damaged by incorrect transport or storage. Inspections should be made by a representative of the manufacturer or the supplier although the company can assign its own suitably trained personnel. Inspections are instigated by the user.

Inspection by a crane expert

If the hoist is used as a crane with a capacity of at least 1000 kg, it has to be inspected and approved by a crane expert before initial operation. This inspection has to be registered in the crane inspection book. The inspection by the crane expert has to be instigated by the operating company.

7. OPERATION

Installation, service, operation

Operators delegated to install, service or independently operate the hoist must have had suitable training and be competent. Operators are to be specifically nominated by the company and must be familiar with all relevant safety regulations of the country of use.

Inspection before starting work

Before starting work inspect the hoist/trolley, chains and all load bearing components every time for visual defects. Furthermore test the brake and make sure that the load and hoist/trolley are correctly attached by carrying out a short work cycle of lifting and lowering resp. travelling in both directions. Selection and calculation of the proper suspension point and beam construction are the responsibility of the operating company.

Inspection of load chain

Inspect the chain for sufficient lubrication and visually check for external defects, deformations, superficial cracks, wear or signs of corrosion.

Inspection of chain end stop

The chain end stop must be connected to the free (idle) chain strand (see Fig. 1 - chain end stop).

Inspection of chain reeving

All units with two or more chain strands should be inspected prior to initial operation for twisted or kinked chains. The chains of 2-strand hoists may be twisted if the bottom block was rolled over (Fig. 11).

The load chain has to be installed according to illustration (Fig. 14). Hereby the welds on the standing links must face away from the load sheave.

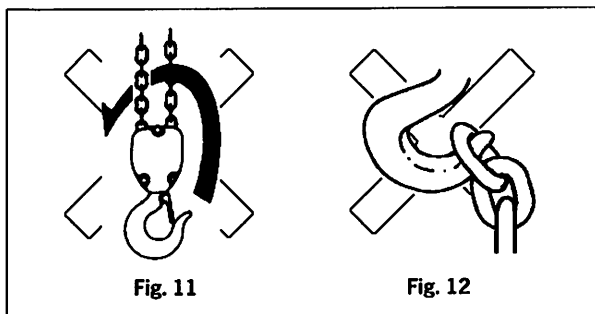

Inspecting the hooks

Check the load hook and the suspension hook for deformations, cracks, damages, abrasion and signs of corrosion.

Attaching the load

The load must always be seated in the saddle of the hook. Never attach the load to the tip of the load hook. This also applies to the suspension hook (Fig. 12).

Inspect the traverse (for trolleys)

Inspect the traverse for correct assembly and visually check for external defects, deformations, superficial cracks, wear or signs of corrosion. Especially make sure that the roll pins are properly fitted to the centre traverse (Fig. 10).

Check adjustment of trolley width

On chain hoists with trolley (CPV/F-VTP/G(E)) check that the clearance between the trolley wheel flange and the beam outer edge is equal on both sides and within the tolerances given (see page 5, Fig. 10).

Enlarging the clearances, e.g. to enable the trolley to negotiate tighter curves, is forbidden.

Traversing the hoist

Plain trolley: Push the hoist or attached load.

Attention: Never pull on the pendant control cable. Suspended loads may only be pushed.

Geared trolley: By operating the trolley hand chain.

Electric trolley: By operating the ▶ resp. ◀ button. For trolleys with two speeds: The first stage of button depression activates the slow speed., further depression activates the fast speed. Use the slow speed for short periods only.



Attaching the load

Attach the load to the hoist using only approved and certified slings or lashing devices. Never use the load chain as sling chain. The load must always be seated in the saddle of the hook. Never attach the load to the tip of the hook. Do not remove the safety latch from the load hook.

Lifting/lowering the load

The load is lifted by depressing the ▲-button, it is lowered by depressing the ▼-button. For hoists with two speeds: The first stage of button depression activates the slow speed, further depression activates the faster speed. In order to raise the load, always use the lowest available lifting speed. The chain must be loaded at this speed and may not lie slack on the floor. The slow speed may only be used for short distances. The chain end stop may not be used as operational limit switch (see Fig. 1). Use the slow speed for short periods only. Do not use the chain end stop as operational limit device.

Emergency stop

All movement can be immediately halted by depressing the red, mushroom shaped button on the pendant control.

Attention: Operating the red emergency button does NOT automatically disconnect the mains supply to hoist or trolley. To release the emergency stop, rotate the button in an clockwise direction.

End limit switch

This hoist is provided with an end limit switch for the lowest and highest hook position as standard. This limit switch is a safety device and may not be used as operational limiting device.

8. SERVICE

- Service and inspections may only be carried out by a competent person.
- The inspection must determine that all safety devices are present and fully operational and covers the condition of the hoist, lifting gear, accessories and supporting constructions.
- The service intervals and inspections noted are for normal working conditions. Adverse working conditions, e. g. heat or chemical environments, can dictate shorter periods.
- The Yale electric chain hoist CPV/F conform to FEM group 1Am in accordance with FEM 9.511. This results in a theoretical service lifetime of 800 operating hours under full load. This is equivalent to 10 years under normal operating conditions. After this period the hoist requires a general overhaul. Further information is contained in BGV D6 resp. FEM 9.755.

Attention: Maintenance work requires subsequent function testing with nominal load.

8.1 DAILY CHECKS

1. Visually check the pendant control switch and cable for damage.
2. Function test of brake
3. Function test of end limit switch
4. Electric chain hoists with trolley:
 - Check that the trolley runway is free from obstructions
 - Check that the end stops on the trolley runway are fitted and secure.

Inspection and Maintenance	Initial checks			Periodical checks		
	during commissioning	after 50 operating hours	after 200 operating hours	daily	after 200 operating hours	annually
Lubricate load chain	•	•	•		•	
Pendant control and support wire	•	•		•		
Check oil level	•	•			•	
Function test of brake	•			•		
Function test of end limit switch	•			•		
Function test of overload device	•					•
Electrical installation and power supply	•					•
Check for wear in chain drive		•	•		•	
Inspect chain bolts for cracks		•				•
Inspect suspension bracket and load hook for cracks and deformation		•				•
Check screwed connections for tightness		•				•
Inspect trolley components for cracks and deformation		•				•
Oil change			•			•
Inspect motor and transmission of hoist						•
Inspect motor and transmission of trolley						•
Adjustment of overload device						•
Adjustment of brake						•
Lubricate geared trolley drive						•